

THIS COPY IS PROVIDED ON A RESTRICTED BASIS AND IS NOT TO BE USED IN ANY WAY DETRIMENTAL TO THE INTERESTS OF PANDUIT CORP.

NOTES:

1. MATERIAL:
BODY - ALUMINUM, TIN PLATED
SCREW - ALUMINUM, TIN PLATED
2. UL LISTED, CSA CERTIFIED, OR cULus FOR USE UP TO 600V & TEMPERATURE RATED 90 °C (AL9CU)
3. DUAL RATED FOR USE WITH COPPER OR ALUMINUM STRANDED CODE CONDUCTOR
4. THESE PARTS ARE RoHS COMPLIANT
5. USE OF OXIDE INHIBITING JOINT COMPOUND LIKE PANDUIT CMP-100 RECOMMENDED FOR PAD TO PAD AND CONDUCTOR SURFACES
6. SEE PACKAGING LABEL FOR TIGHTENING TORQUE INFORMATION
7. PKG QTY:
6 = 6

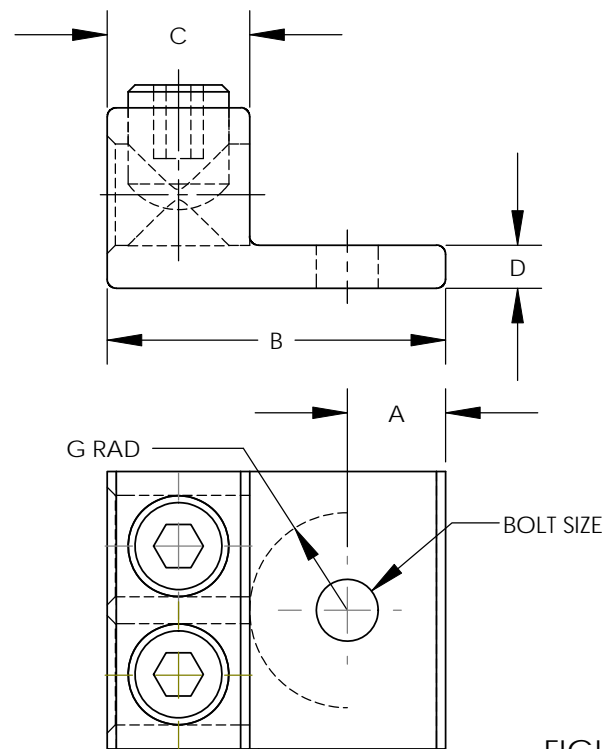

FIGURE 1 **L**

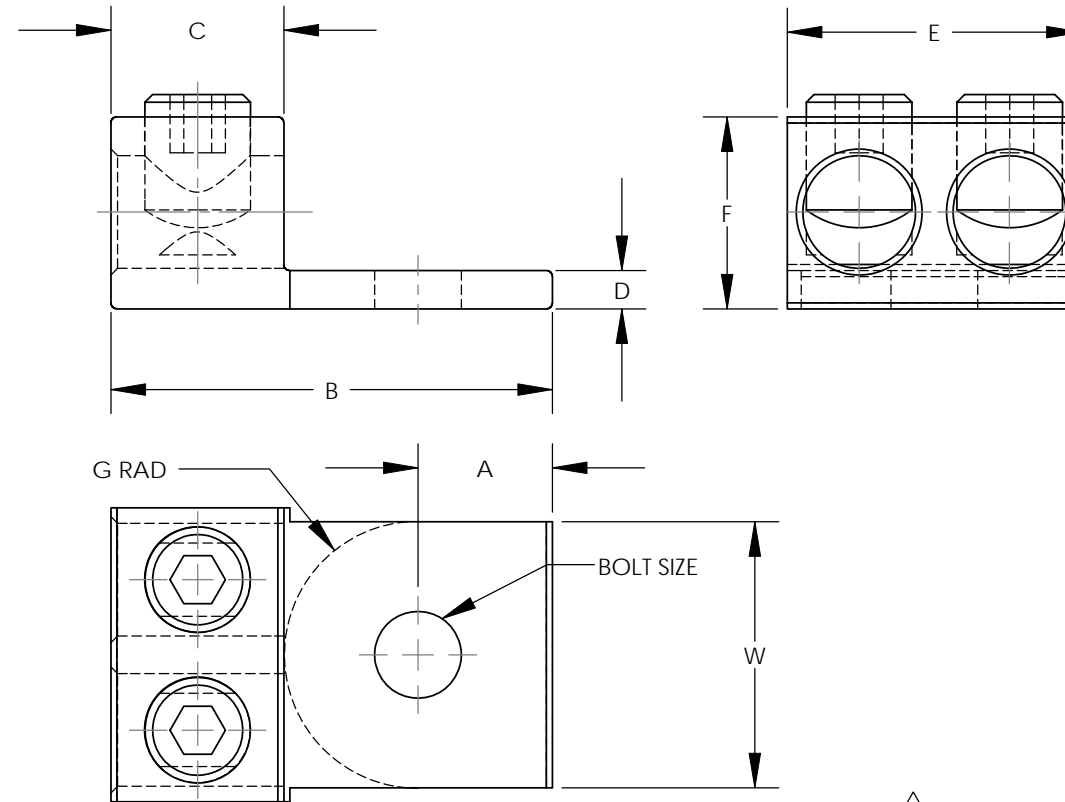
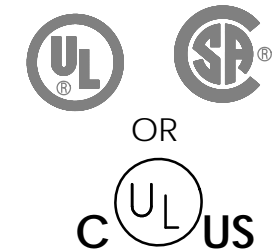

FIGURE 2 **L**



PART NUMBER	FIG.	WIRE RANGE COPPER/ALUMINUM	WIRE STRIP LENGTH IN[mm]	STUD SIZE IN	DIMENSIONS - IN [mm]								HEX KEY*	AGENCY
					A	B	C	D	E	F	G	W		
E LAM2A 1/0-14-6Y	1	14 AWG - 1/0 AWG	.62 [15.7]	1/4	0.43 [10.8]	147 [37.3]	0.62 [15.7]	0.19 [4.8]	113 [28.6]	0.78 [19.9]	0.42 [10.7]	N/A	SLOTTED	cULus
D LAM2A 2/0-14-6Y	1	14 AWG - 2/0 AWG	.62 [15.7]	1/4	0.43 [10.8]	147 [37.3]	0.62 [15.7]	0.19 [4.8]	120 [30.6]	0.78 [19.9]	0.42 [10.7]	N/A	3/16	cULus
C LAM2A 250-38-6Y	2	6 AWG - 250 kcmil	100 [25.4]	3/8	0.51 [13.0]	2.56 [65.1]	100 [25.4]	0.25 [6.4]	164 [41.7]	1.19 [30.2]	1.05 [26.7]	150 [38.0]	5/16	cULus
B LAM2A 350-12-6Y	2	6 AWG - 350 kcmil	113 [28.6]	1/2	0.88 [22.2]	2.87 [73.0]	113 [28.6]	0.25 [6.4]	191 [48.6]	1.25 [31.8]	0.86 [21.8]	173 [44.0]	5/16	cULus
K J LAM2A 600-12-6Y	2	2 AWG - 600 kcmil	138 [34.9]	1/2	0.63 [16.0]	3.19 [81.0]	138 [34.9]	0.44 [11.2]	2.38 [60.5]	1.56 [39.6]	1.19 [30.2]	2.00 [50.8]	3/8	UL & CSA
H I LAM2A 1000-58-6Y	1	500 kcmil - 1000 kcmil	163 [41.4]	5/8	0.88 [22.2]	3.50 [88.9]	163 [41.4]	0.50 [12.7]	3.50 [88.9]	1.94 [49.3]	1.00 [25.4]	N/A	3/8	UL & CSA

* HEX SIZE MAY DIFFER FROM CHART. DIFFERENCE IN SIZE WILL NOT AFFECT FIT, FORM, OR FUNCTION OF PART

10N006AT-NC/01B **F**

PANDUIT CORP. TINLEY PARK, ILLINOIS

LAM2A SERIES
ALUMINUM MECHANICAL LUGS
CUSTOMER DRAWING

UNLESS OTHERWISE SPECIFIED
DIMENSIONAL TOLERANCES ARE:
(.X) ± ... (.XXX) ± ...
(.XX) ± ... ANGLES ± ...

UNLESS OTHERWISE SPECIFIED,
ALL DIMENSIONS ARE GIVEN IN
INCHES, THIRD ANGLE PROJECTION

DRAWN BY
JHNU

MAT'L:

SCALE NONE

06 10/10 JHNU JHNU M. ADDED AGENCY COLUMN TO TABLE
L. REMOVED MARKINGS FROM PART VIEWS

10N006AT-NC FLD FLD DATE 2/06

SEE NOTES

DRAWING NO / CAD FILE DWG
10N006AT-NC B
SIZE

REV DATE BY CHK DESCRIPTION

ECN -R SUP CHK'D

F